



Midlands  
Orthopaedic Centre

# Fracture Clinic

Advice after a radial head, neck, elbow  
fracture

Patient Information Leaflet



The Dudley Group  
NHS Foundation Trust

## Introduction

You have a very small break at your elbow. This is in the radial head or neck, one of the bones in your elbow (see figure 1).

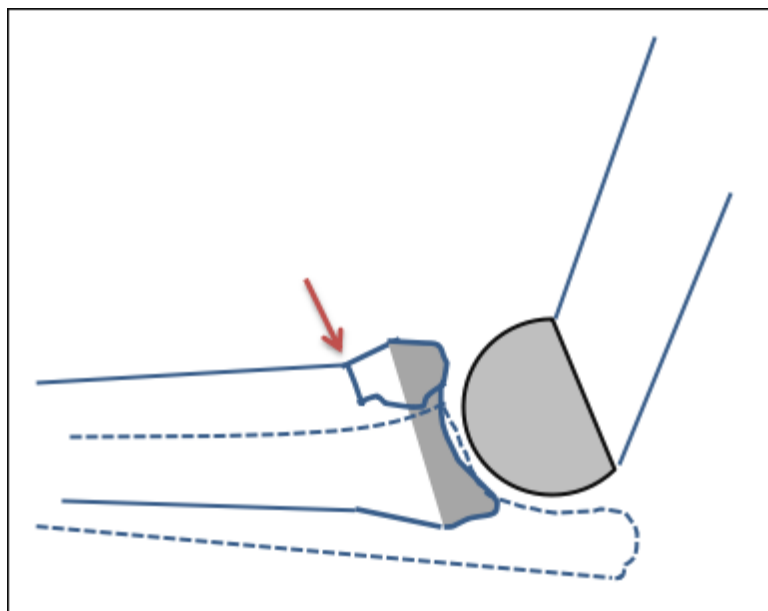

Figure 1 shows where the break is in your elbow

These fractures almost always heal well with time and use. No specific treatment is required and therefore, routine follow-up is not needed.

## What should I do at home?

A sling will hold your elbow in a comfortable position for a few days. You should wean yourself off this as your pain settles and aim to remove the sling completely as soon as you feel able. At first, you may need to take painkillers as it is important to keep gently moving the elbow. We suggest paracetamol or ibuprofen, if you can take them (always read the label; do not exceed the recommended dose).

You should gradually resume daily activities within the limits of discomfort. This will prevent stiffness and ensure the quickest return to normal function. Forcing it to stretch is unnecessary, and is likely to cause pain and delay your recovery.

## How long will it take to heal?

Symptoms are usually minor but may take up to three to six weeks to settle. There may be slightly reduced movement at the elbow, especially on straightening it, but this is unlikely to affect its function.

**If you have any worries or concerns, or need to ask about returning to work or sport, please contact one of the following:**

- Virtual Fracture Clinic helpline on ext. 3547 (9am to 5pm, Monday to Friday)  
Or email [dgft.vfc.dudley@nhs.net](mailto:dgft.vfc.dudley@nhs.net)
- Fracture Clinic on 01384 456111 ext. 2220 (9am to 5pm, Monday to Friday)
- Emergency Department on 01384 456111 ext. 2300

**This leaflet can be downloaded or printed from:**

**<http://dudleygroup.nhs.uk/patients-and-visitors/patient-information-leaflets/>**

If you have any feedback on this patient information leaflet, please email [dgft.patient.information@nhs.net](mailto:dgft.patient.information@nhs.net)

**This leaflet can be made available in large print, audio version and in other languages, please call 0800 073 0510.**

للحصول على هذه النشرة بحجم أكبر، وعلى شكل إصدار صوتي و بلغات أخرى، الرجاء الاتصال بالرقم 08000730510.

此宣传单可提供大字版本、音频版本和其它语言版本，请拨打电话：0800 073 0510。

Ulotka dostępna jest również w dużym druku, wersji audio lub w innym języku. W tym celu zadzwoń pod numer 0800 073 0510.

ਇਹ ਪਰਚਾ ਵੱਡੇ ਅੱਖਰਾਂ, ਬੋਲ ਕੇ ਰੀਕਾਰਡ ਕੀਤਾ ਹੋਇਆ ਅਤੇ ਦੂਸਰੀਆਂ ਭਾਸ਼ਾਵਾਂ ਵਿਚ ਵੀ ਪ੍ਰਾਪਤ ਹੋ ਸਕਦਾ ਹੈ, 0800 073 0510 ਤੇ ਫੋਨ ਕਰੋ ਜੀ।

Aceasta broșura poate fi pusă la dispoziție tipărită cu caractere mari, versiune audio sau în alte limbi, pentru acest lucru va rugăm sunați la 0800 073 0510.

یہ کتابچہ آپ کو بڑے حروف کی لکھائی، سمعی صورت اور دیگر زبانوں میں مہیا کیا جا سکتا ہے۔ براہ کرم مہربانی فون نمبر 08000730510 پر رابطہ کریں۔